



**MOTOROLA**  
*intelligence everywhere™*

# Commercial Series

## CM340

User Guide

6866545D05 - O

Issue: October 2003

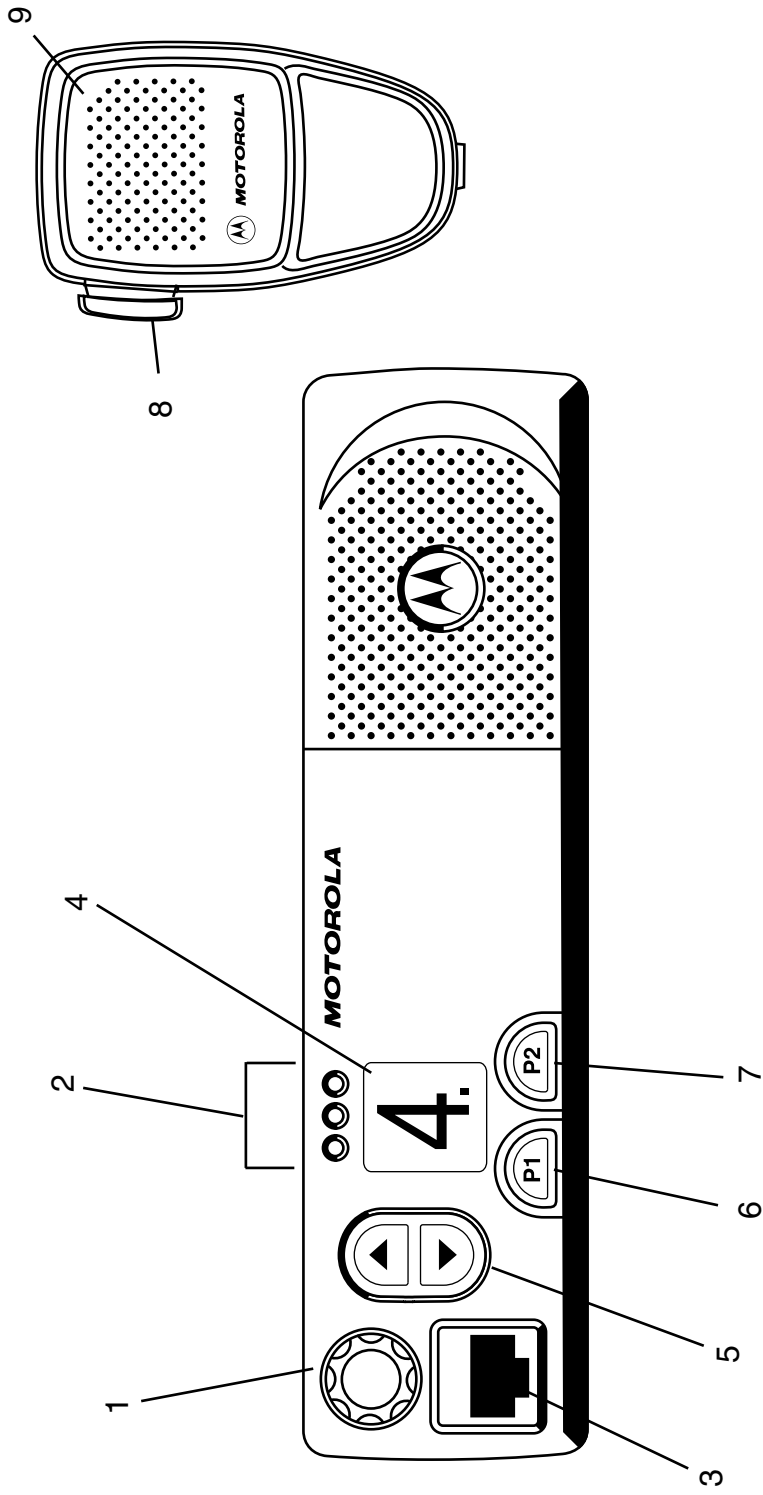

## CONTENTS

<b>Radio Overview</b> .....	<b>3</b>
Radio Controls .....	3
Microphone Controls .....	3
Programmable Buttons .....	4
LCD Display .....	6
Scroll Keys .....	6
Audio Signal Tones .....	7
LED Indicators .....	8
<b>Getting Started</b> .....	<b>9</b>
Turning the Radio On-Off .....	9
Adjusting the Radio's Volume .....	9
Radio On Indication .....	9
Selecting a Radio Channel .....	10
Memory Channel .....	11
Sending a Call .....	11
Receiving a Call .....	12
Cancelling a Call .....	12
Ending a Call .....	12

<b>Radio Calls</b> .....	<b>13</b>
Selective Calls .....	13
Making a Selective Call .....	13
Receiving a Selective Call .....	13
Emergency Calls .....	14
<b>Features</b> .....	<b>15</b>
Public Address Mode .....	15
Car Radio Mute .....	16
<b>Utilities</b> .....	<b>17</b>
Scan .....	17
Call Forward .....	18
Talkaround .....	19
External Alarm .....	19
Lone Worker .....	20
Power Level .....	20
Companding .....	21
Local/Distance .....	21
Voice Operated Transmit (VOX) .....	22
Stun/Unstun .....	22

## **Computer Software Copyright**

The products described in this manual may include copyrighted computer programmes stored in semiconductor memories or other media. Laws in the United States of America and other countries preserve for Motorola Europe and Motorola Inc. certain exclusive rights for copyrighted computer programmes, including the right to copy or reproduce in any form the copyrighted computer programme. Accordingly, any copyrighted computer programmes contained in the products described in this manual may not be copied or reproduced in any manner without the express written permission of the holders of the rights. Furthermore, the purchase of these products shall not be deemed to grant either directly or by implication, estoppel, or otherwise, any licence under the copyrights, patents, or patent applications of the holders of the rights, except for the normal non-exclusive royalty free licence to use that arises by operation of the law in the sale of the product.

## RADIO OVERVIEW

This user guide covers the operation of the CM340 Mobile Radio.



**Caution**

Before using this product, read the operating instructions for safe usage contained in the Product Safety and RF Exposure booklet 6866537D37\_ enclosed with your radio.

### ATTENTION!

This radio is restricted to occupational use only to satisfy ICNIRP RF energy exposure requirements. Before using this product, read the RF energy awareness information and operating instructions in the Product Safety and RF Exposure booklet (Motorola Publication part number 6866537D37\_) to ensure compliance with RF energy exposure limits.

### RADIO CONTROLS

The numbers below refer to the illustrations on the inside front cover.

- 1. On-Off / Volume Knob**  
Used to turn the radio on or off, and to adjust the radio's volume.
- 2. LED Indicators**  
Indicates channel, scan, and monitor status, as well as receipt of a selective call.

- 3. Mic Jack**

- 4. LCD Display**

A single digit display used for digits 0 to 9. The display also shows a dot used to indicate radio power Hi/Lo condition.

- 5. Up/Down keys**

Used for channel scrolling.



- 6. Programmable Button 1**

- 7. Programmable Button 2**

### MICROPHONE CONTROLS

Hold the microphone 2.5 to 5 cm (1-2 inches) from your mouth, and speak clearly into it.

- 8. Push-to-talk (PTT)**

Press and hold down this button to talk; release it to listen.

- 9. Microphone**

### PROGRAMMABLE BUTTONS

Several of your radios keys and buttons can be programmed, by Customer Programming Software (CPS), as short -cut buttons for many of the radio's features. Programmable buttons include:

**CM340**  

Each button is dual function; a short press may select one function, a long press may select the second.

Check with your dealer for a complete list of the functions your radio supports.

Feature	Description	Selection
Monitor 1/Cancel	Monitor 1 allows you to select between signalling squelch, carrier squelch and unsquelch, and to suspend scan when landed on a channel in scan mode. Cancel allows you to cancel an incoming or outgoing call.	Short or Long
Monitor 2/Cancel	Monitor 2 opens squelch regardless of signalling or carrier present. Cancel allows you to cancel an incoming or outgoing call.	Long
Call 1, 2, 3 and 4	Allows you to transmit assigned calls. Two calls may be allocated to one button, using the short/long press for selection.	Short or Long
Memory Channel (1 & 2)	Provides direct channel access on a single button press.	Short or Long
Store Memory Channel (1 & 2)	Programs a button to provide direct channel access.	Long
Scan (On/Off)	Toggles between start and stop of the scan operation.	Short or Long

Feature	Description	Selection
Nuisance Delete	To delete a nuisance (unwanted) channel when scanning, with exception of priority channel, last channel in scan list and home channel.	Short or Long
Emergency	Activates emergency alarm sequence.	Long: On Off: depending on Programme
Lone Worker (On/Off)	To identify user as a lone worker. Radio enters emergency sequence unless user responds, when prompted, by pressing any radio button.	Short or Long
Power Level (Hi/Low)	Toggles the radio's transmit power level between High and Low.	Short or Long
Talkaround (On/Off)	Sets the transmit channel frequency to the same as the receive channel frequency to talk directly with another radio without going through a system or despatcher.	Short or Long
Call Forward (On/Off)	Transfers calls automatically to another radio if you are unable to take the call.	Short or Long
Xpand (On/Off)	Toggles between compression/expansion of audio signal and normal audio signal.	Short or Long
External Alarm (On/Off)	Toggles the External Alarm feature on and off. Note: May be programmed as permanently On.	Short or Long
Local/Distance	Toggles between Local and Distance. Local reduces interference from other radios in close proximity and is used for base stations. Distance improves the radio range.	Short or Long

## LCD DISPLAY



Displays the radio operating Channel.

A dot is also displayed at the bottom right hand corner of the display to indicate that High Power is selected.



When Talkaround mode is selected, the channel number will flash.

When high power operation is selected, the 'dot' after the channel number will light.

During the Power-up self test routine, should a failure occur, the self test failure number will be displayed.

**Note:** At extremely low temperatures, you may experience a slight delay in displaying new information. This is normal and does not affect the function of your radio.

## SCROLL KEYS

Up /Down Keys  

Used to increment/decrement channel number.







### AUDIO SIGNAL TONES

High pitched tone  Low pitched tone

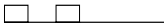
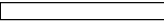
Tone	Signal	Description
Power up OK		Radio self-test OK.
Power up Fail		Radio self-test fail.
Button/ Keypad Error		Button/keypad key/ menu key press not permitted.
Engaged		Channel busy or not permitted to transmit.
Call Failed		Call failed to connect.
Force Monitor		Radio must monitor channel before transmission permitted.
Button Feature Enable		Any option button pressed to enable a feature.

Tone	Signal	Description
Button Feature Disable		Any option button pressed to disable a feature.
Group Call		Radio receives a Group Call.
Individual Call		Radio receives an Individual Call.
Call Reminder		Reminder of unanswered call.
TOT Pre-Alert		Warns of expiry of time out timer.
Monitor Alert		Alerts to change of squelch.
Scan Start		Radio starts scanning.
Scan Stop		Radio stops scanning.
Priority Call Decode		Radio detects a priority call.

Tone	Signal	Description
Priority Channel		Radio landed on the priority channel.
Lone Worker		Reminds lone worker to respond.
Hardware Error		Hardware error, tone continues until valid operation.
Channel Free Beep		Indicates current channel is free.
Incoming Emergency Alert		Indicates an emergency situation.
Keypad Acknowledge		Confidence tone when any key pressed.
Ringtones	English/French/General	Incoming calls (high tones), outgoing calls (low tones).

### LED INDICATORS

Three LEDs show radio status as follows:

LED	State	Indication
Green	Solid	Successful power up.
Green	Off	After successful power up.
Green	Flashing	Radio is scanning.
Red	Solid	Radio transmitting.
Red	Flashing	Channel busy - when receiving.
Yellow	Solid	Radio in monitor mode or selectively called.
Yellow	Flashing	Group call reminder - after answer timer expires.
Yellow	Double Flash	Individual call reminder - after answer timer expires.

## GETTING STARTED

### TURNING THE RADIO ON / OFF

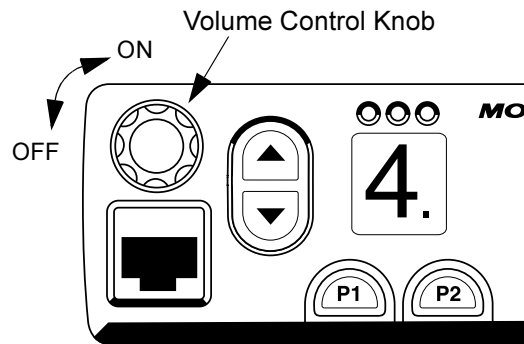

ON	OFF
Rotate the <b>On/Off/Volume Control</b> knob clockwise until you hear a click.	Rotate the <b>On/Off/Volume Control</b> knob counterclockwise until you hear a click. The display clears and the LED indicators turn off .

### ADJUSTING THE VOLUME

Turn the **On/Off/Volume Control** knob clockwise to increase the volume, or counterclockwise to decrease the volume.

### RADIO ON INDICATION

At power up the radio performs a self test routine. During the routine the Green LED lights. On completion of a successful self test the radio produces the Self-Test pass Tone, the Green LED indicator goes out and the display shows the Channel that was in use at power down, typically:

5

**Note:** If your radio fails the self test routine the display will show the failure number. Record the number and consult your dealer.



## SELECTING A RADIO CHANNEL

Your radio offers up to 10 channels, however some may not be programmed. Check with your dealer for more information.

Your radio will power up on the channel that was in use when the radio was powered down or it will power up on a designated pre-programmed channel.

### To Change Channels

#### Channel Scroll Up/Down Buttons

Press  to increment the Channel number or  to decrement it.

#### Memory Channel Buttons

If P1 or P2 have been programmed as “Memory Channel” buttons, an appropriate press on the button will select the programmed channel. (see Memory Channel below).

## MEMORY CHANNEL

The programmable buttons (P1 and P2) can be programmed as Memory Channel buttons which allow you quick access to frequently used channels. The buttons may be pre-programmed by your dealer or are programmable by yourself.

If pre-programmed by your dealer, an appropriate press of the button will take you to the assigned channel.

To program a Memory Channel button yourself, select the desired channel in the normal way and long press the button. The button is then programmed to the selected channel; a short press on the button will take you to that channel.

**Note:** The programming is retained when you turn off the radio.

## SENDING A CALL

1. Select the desired radio channel.
2. Press the **PTT** button and speak clearly into the microphone. Your mouth should be 2.5 to 5 cm away from the microphone.
3. When transmitting, the red indicator will light continuously.
4. Release the **PTT** button to listen.

Your radio may be configured for 'Transmit Inhibit' under certain conditions (e.g. when the channel is in use by others) in which case, the channel busy tone will sound when you press the PTT or call button to indicate that transmission is inhibited.

When the channel is free, the Channel Free beep  will sound, and you can make a call.

If your radio is equipped with a transmit time-out timer (TOT), a warning tone  will sound a few seconds before the transmission is cut off. Your radio may be programmed to inhibit re-transmission within a preset time.

**RECEIVING A CALL**

1. Turn your radio on and adjust the volume level.
2. Switch to the desired radio channel.
3. If, at any time, a call is received you will hear the call at the volume level you have set.

**Note:** The system may have a limited call time and the call may be terminated automatically if this call time is exceeded.

**CANCELLING A CALL**

A call may be cancelled at any time, while setting up, by replacing the microphone in its holder (referred to as going “on hook”) or pressing the Monitor/Call Cancel button (if programmed).  
The call timer can also cancel a call.

**ENDING A CALL**

A call should always be ended by pressing the Monitor/Call Cancel button, or replacing the microphone in its holder.

## RADIO CALLS

### SELECTIVE CALLS

#### Making a Selective Call

You can make a selective call to a particular radio, known as an individual call, or a group of radios, known as a group call.

To make a Selective Call:

1. Press the PTT or Call Button (depending on the way your radio has been programmed by your dealer), to set up the call.
2. Wait until the conversation has been set up, which means that you are authorised to use the system.
3. Talk with your mouth 2.5 - 5.0cm from the microphone. Release PTT to listen.
4. When transmitting, the red indicator will light continuously.

#### Receiving a Selective Call

When you receive a selective call, you will hear either,

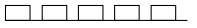
an individual call alert tone  ,

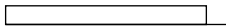
or a group call alert tone .



The yellow LED Indicator will light.

#### Answering a Call

To answer the call:

1. Press the PTT button or Call button.
2. The call will terminate automatically when the conversation has ended or press the Monitor/ Call Cancel button

## EMERGENCY CALL

Your radio can be programmed (buttons  or ) to give you a one-button quick access to call a particular radio or centre (predefined by your dealer) in emergency situations. This is the *Emergency Call*. The call can only be programmed to operate with a long press.

When you make an Emergency call, your radio goes into an Emergency state, which can be programmed to:

- continually receive speech,
  - the radio can receive and transmit.
1. Use a long press on the **Emergency** button to initiate the Emergency call.
  2. Emergency can be stopped by:
    - Switching the radio **Off** and **On** again.
    - A **reset** message received by your radio.
    - The emergency time duration is reached.

**Note:** The emergency time duration and reset message are programmed into your radio by your dealer.

Should you receive an Emergency call the incoming emergency alert tone    will sound.



## FEATURES

### PUBLIC ADDRESS MODE

The Public Address mode allows you to use your radio audio as a public address system. You can use your radio microphone as normal and the audio is routed through the radio to an external loudspeaker fitted to your vehicle.

A switch, external to your radio, switches the audio from your radio to the external loudspeaker.

This feature is programmed and fitted by your dealer.

To access the Public Address system:

1. Turn external switch to the **PA** position.
2. Press microphone PTT and talk.
3. To exit PA mode, turn the external switch to the **RADIO** position.

**Note 1:** While in PA mode you can still hear incoming radio calls as long as you **do not** press the PTT.

**Note 2:** You must exit PA mode in order to answer or make radio calls.

### **CAR RADIO MUTE**

The Car Radio Mute feature automatically mutes your in-car audio entertainment system to allow you to hear incoming calls or to stop audio interference when you are making a call.

This feature may be programmed into your radio by your dealer.

## UTILITIES

The utilities described below are programmed into your radio by your dealer and are accessible via a programmable button.

### SCAN

You can monitor several channels in order to receive any call that is transmitted on any of these channels. Eight different channels can be programmed into each scan list. Each channel can share the same scan list or have different scan lists assigned to them.

Once the radio's scan operation is activated and the radio detects a call coming through a channel in its scan list, it switches to that channel for you to receive the call.

### Starting or Stopping Scan

You can start or stop a scan operation by using a pre-programmed **Scan** button either when the radio is in the IDLE STATE or when in a call.

### Using the Scan Button

1. Press the **Scan** button to start scanning. The scan start alert tone  $\square \square \square \square$  will sound.
2. Press the **Scan** button again to stop scanning. The scan stop alert tone  $\blacksquare \blacksquare \blacksquare \blacksquare$  will sound.

The scan start alert tone will sound and the Green LED indicator will blink during a scan operation. When a call on a channel is detected the LED will stop blinking and the channel number will be displayed.

### Priority Channel

A scan list may contain a priority channel. This means that a particular channel (for example, a commonly used channel) may be checked more frequently than other channels in the list during a scan operation. Priority channels are programmed into your radio scan lists by your dealer.

### Talkback

If the programmable Talkback option is set, you can respond to any calls received during the scan operation by pressing the PTT button before the programmed hang-time ends. Check with your dealer for details.

### Deleting a Nuisance Channel

If a channel continually generates unwanted calls/noise (a “nuisance” channel), you can temporarily remove it from the scan list by performing a *Nuisance Channel Delete* operation:

1. While the radio is on the Nuisance Channel, press the **Nuisance Delete** button until you hear the scan start alert tone.

**Note:** You cannot perform a Nuisance Channel Delete on a priority channel or if there is only one remaining channel in the scan list.

### Adding A Deleted Nuisance Channel Back Into The Scan List

1. Press the **Scan** button to stop scanning. The scan stop alert tone will sound.
2. Press the **Scan** button again to re-start scanning. The scan start alert tone will sound, and the scan list will contain all programmed channels.

### CALL FORWARD

You can call forward calls to your radio to another radio if you are unable to take calls or are away from your radio.

You can switch Call Forward **On** or **Off** by using a pre-programmed **Call Forward** button.

1. Press the **Call Forward** button to switch **on** Call Forward, when the feature enable alert tone will sound.
2. Press the **Call Forward** button again to switch **off** Call Forward when the feature disable alert tone will sound.

## TALKAROUND

In your communications network, you may be using a system to cover a larger area than is possible with your radio. However, you can communicate with another radio within your radio's range without going through the system by using the Talkaround feature. This is especially useful when the system is down. You can switch Talkaround **On** or **Off** by using a pre-programmed **Talkaround** button.

1. Press the **Talkaround** button to switch **on** Talkaround when the feature enable alert will sound.
2. Press the **Talkaround** button again to switch **off** Talkaround when the feature disable alert will sound.

## EXTERNAL ALARM

The external alarm feature activates the vehicle horn and/or lights to inform you of an incoming call when you are away from your vehicle. You can switch External Alarm **On** or **Off** by using a pre-programmed **External Alarm** button. Alternatively the alarm may be programmed permanently **On** by your dealer.

1. Press the **External Alarm** button to switch External Alarm **on**, when the feature enable alert tone will sound.
2. Press the **External Alarm** button again to switch External Alarm **off**, when the feature disable alert will sound.

An activated alarm can be cancelled by:

1. Answering the call.
2. The external alarm timer times out.

**Note:** If programmed permanently **On** by your dealer, the alarm will be active and generate an alarm when you receive a call.

## LONE WORKER

The Lone Worker feature enables you to work alone with added safety. You can switch the feature **On** or **Off** by using a pre-programmed **Lone Worker** button.

### Switching Lone Worker On

1. Press the **Lone Worker** button to switch Lone Worker **on**, when the feature enable alert will sound.
2. If you have not pressed any buttons within a programmed time, you will be reminded that **Lone Worker** is switched **on** by a high pitched alert tone (Lone Worker Reminder) being sounded.
3. Press **any button** to respond and cancel the alert, if you do **not** the radio will enter the Emergency state.

### Switching Lone Worker Off

1. Press the **Lone Worker** button again to switch Lone Worker **off**, when the feature disable alert will sound.
2. You may also switch off Lone Worker by changing the channel or switching radio **off** and **on** again.

## POWER LEVEL

You can transmit your calls at different transmit power levels. A higher level means you can reach a radio that is farther away. A lower power level reduces the possibility of interference. Use the high power setting only when necessary.

You can switch between **high** and **low** power levels by using a pre-programmed **Power Level** button.

### Using the Power Level Button

1. Press the **Power Level** button to switch to **high power** when the feature enable alert will sound and the display will show a dot in the bottom right hand corner.
2. Press the **Power Level** button again to switch to **low power** when the feature disable alert will sound and the "High Power " dot on the display will go out.

## COMPANDING

Companding is a collective term to define **compressing** the audio signal on transmission and **expanding** the audio signal on reception. The overall effect is to reduce noise in the received signal, giving you crisper, clearer audio clarity. Companding should only be used when other radios in your system have the same companding feature available.

You can switch Companding **On** or **Off** by using a pre-programmed **Companding** button.

1. Press the **Companding** button to switch Companding **on**, when the feature enable alert will sound.
2. Press the **Companding** button again to switch Companding **off**, when the feature is disabled an alert will sound.

## LOCAL / DISTANCE

Distance is the standard mode of operation, and maximises receive radio range.

Local reduces interference from other radios in close proximity and is typically used for base station configurations.

You can switch between **Local** and **Distance** by using a pre-programmed **Local/Distance** button.

### Using the Local/Distance Button

1. Press the **Local/Distance** button to switch to **Local** when the feature enable alert  will sound.
2. Press the **Local/Distance** button again to switch to **Distance** when the feature disable alert  will sound.



### VOICE OPERATED TRANSMIT (VOX)

When the VOX accessory is connected, your radio may be used with hands-free operation.

The VOX feature intelligently senses background noise, so that it adapts automatically to the noise level in the environment in which you are working.

To start the VOX feature:

1. Ensure that the VOX accessory is connected to the rear accessory connector of the radio.
2. Switch the radio to a VOX channel.

You can disable the VOX feature by pressing the PTT button on the hand held microphone. This allows you to use the hand held microphone as normal.

To re-enable the VOX feature:

1. Change channel away from and back to the VOX channel.

### STUN/UNSTUN

For added security and to avoid abuse of the radio system in which you operate, a feature known as **Stun/Unstun** is included in your radio.

This feature can only be activated by your system manager or administrator.

For example, if your radio is stolen and is being used illegally, your system administrator can send a signal which will **stun** the radio making it incapable of being used. This feature is also useful if the system is being abused by a user who is not complying with the correct communications protocol.

The radio can only be unstunned, i.e. returned to operational use, by an **unstun** signal sent from the system administrator or returning the radio for reprogramming.